

# Perception of Employees Attitude towards Team Leaders with Special Reference to IT Companies in Chennai

**Dr.P.Jegatheeswari**

Research Supervisor & Associate Professor  
Department of Management Studies  
Bhaktavatsalam Memorial College for Women  
Korattur, Chennai – 600 080.

**Abstract:** In the fast developing world of today, there are many industries that are growing rapidly. One of the fastest developing industries is the I.T. Industry. The present study will try to identify the factors that influences the perception of the employees towards the attitude of the team leaders. A team leader is responsible in every way to extract work from his/her subordinate employees, but at the same time it is his responsibility to keep them satisfied and happy so that they will remain efficient to the companies that employ them. If the team manager is incompetent, the subordinates will bear the brunt of heavy stress and eventually a complete loss of efficiency. But if the team leader is efficient and competent, he might help the subordinate employees to escape depression and maintain their efficiency as long as they are employed. Therefore, the role of the team leader becomes paramount in maintaining the efficiency of the employees in the field of I.T. industries. The type of research is descriptive. For the present kind of research, 384 samples are the minimum number, but for the sake of accuracy the researcher has targeted 500 sample respondents from Chennai city. Out of 500 filled questionnaire, only 430 respondents were found to be completed. However, respondents have been selected by snow ball method from non-probability technique. There are previous studies in the field that focused on the problems in the I.T. Industry, but not many of them focused on the role of the Team Leader. The present research is trying to fill that gap by focusing on the role of the Team Leader. It has provided some suggestion too such as the necessity to treat all the employees equally and so on, separately for the employee, team leader and the company.

**Keywords:** Perception Management, Team Leader Role, Job factors, Compensation factors, Environmental factors.

## Introduction

The present study begins with analysing the various facilities and equipment available in a company that might have an effect upon the employees. The study tries to find out if these facilities help the employees to have a positive impact or a negative impact towards either decrease their depression or increase their depression. Similarly there are other problems like the constant threat of losing the job, ever-increasing competition from the new graduates who are coming out of the colleges every year, the ever-growing technology in the field, the constant pressure from the employers to deliver, to deliver within the time limit, not just delivering the products but making them satisfactory, to maintain the work-life balance, to maintain the personal well-being; both physically and mentally, etc. these are some of the problems that might lead to depression of the employees and can create negative perception of the team leader and the company.

## OBJECTIVES OF THE STUDY

1. To study the demographical profile of the I.T Employees in Chennai.
2. To analyse the I.T employees perception and level of satisfaction towards their organizational factors.
3. To evaluate the I.T employees perception towards their team leaders attitude.

## DATA ANALYSIS AND INTERPRETATION

Table

The profile of individual Gender, Age, Marital status, Educational Qualification and Monthly Salary

Particulars	Frequency	Percent
<b>Gender</b>		
Male	252	58.6
Female	178	41.4
<b>Age (in years)</b>		
Below 30 years	68	15.8
30 - 40 years	131	30.5
40 - 50 years	163	37.9
Above 50 years	68	15.8
<b>Marital status</b>		
Married	166	38.6

<b>Bachelor</b>	218	50.7
<b>Widow / Legally separated</b>	46	10.7
<b>Educational qualification</b>		
<b>U.G</b>	225	52.3
<b>P.G</b>	161	37.4
<b>ITI / Diploma</b>	44	10.2
<b>Monthly Salary</b>		
<b>Up to 40,000</b>	108	25.1
<b>40001-80,000</b>	180	41.9
<b>Above 80,000</b>	142	33.0
<b>Total</b>	<b>430</b>	<b>100.0</b>

Source: primary data

The above table explains the profile of individual age, marital status and education. Among the 430 respondents the majority 58.6 percentages are male respondents and the remaining 41.4 percentage respondents are female respondents.

The second table, it is given that among the 430 respondents, the majority 37.9 percent respondents are from the age group of 40 to 50 yrs. the next 30.5 percent respondents are in between the age of 30 to 40. The following 15.8 percent respondents are below the age group of 30yrs. Then the same 15.8 percent respondents are above the age group of 50yrs.

The third table expresses the marital status of the respondents. Of all the 430 respondents, the majority 50.7 respondents are bachelors and the next 38.6 percent respondents are married people. The rest 10.7 percent respondents are legally separated people. The fourth table explains about the educational qualification of the respondents. On analysing all the 430 respondents the majority 52.3 percent respondents are undergraduates and the next 37.4 percent respondents are Post graduates. The left 10.2 respondents have finished ITI/Diploma.

Then the fifth table expresses the Monthly salary of the respondents. Of all the 430 respondents, the majority 41.9 respondents are Rs.40,000 to 80,000 and the next 33.0 percent respondents are above 80000. The rest 25.1 percent respondents are Up to Rs.40,000.

**Table**  
**The profile of individual Occupation, Experience and Designation**

<b>Particulars</b>	<b>Frequency</b>	<b>Percent</b>
<b>Occupation category</b>		
<b>Contract / Temporary</b>	172	40.0
<b>Permanent</b>	258	60.0
<b>Experience (IN years)</b>		
<b>Below 5 years</b>	103	24.0
<b>5 - 10 years</b>	167	38.8
<b>10 - 20 years</b>	129	30.0
<b>above 20 years</b>	31	7.2
<b>Designation</b>		
<b>Software Tester</b>	94	21.9
<b>Software Developer</b>	137	31.9
<b>Technical Writer</b>	78	18.1
<b>Support Engineer</b>	121	28.1
<b>Total</b>	<b>430</b>	<b>100.0</b>

Source: primary data

The above mentioned table explains about their occupation, experience and Designation. On comparing all the 430 respondents, the majority 60 percent respondents are permanent and the rest 40 percent respondents are either in contract or temporary workers.

The second table says about the experience of employees. Of the total 430 respondents, the majority 38.8 percent respondents are having 5 to 10 yrs of experience and the following 30 percent respondents are having the experience of 10 to 20 years. The next 24 percent respondents have below five years experience. And the rest 7.2 percent respondents have 20 and more than 20 years of experience.

The following table explains the designation of the employers. On calculating all the 430 respondents, the majority 31.9 percent respondents are Software Developers and the next 28.1 respondents are Technical writers. Then the following 21.9 percent respondents are Software Testers. And the rest 18.1 are Support Engineers.

#### Exploratory factor analysis for employees' satisfaction on organisational factors in I.T industry.

Factor analysis is a data reduction technique that can reduce the number of items by grouping them and by examining the content of the items in each group one can determine the structure or composition of each group thereby giving a better explanation of the data. It is important to note that factor analysis is not used in prediction or explaining the relationship between different sets of variables, nor is it used to determine group differences. The goal is to explain the underlying structure or composition of the data; therefore we are dealing only with one set of variables.

#### KMO and Bartlett's Test

KMO and Bartlett's Test		
Kaiser-Meyer-Olkin Measure of Sampling Adequacy.		.910
Bartlett's Test of Sphericity	Approx. Chi-Square	6364.171
	df	105
	Sig.	0.000

**Table No. 4.3.1**  
**Rotated Component Matrix Table**

Rotated Component Matrix <sup>a</sup>					
	Component				Communalities
	Factor 1	Factor 2	Factor 3	Factor 4	
Pay leave facilities	.882	.210	.194	.125	.788
Hygiene work facilities	.853	.220	.155	.192	.881
Travel facilities	.841	.188	.176	.169	.825
Recreation facilities	.831	.252	.182	.109	.807
Company Image	.233	.859	.229	.208	.803
Role Clarity	.248	.853	.188	.191	.876
Work Climate	.261	.848	.269	.184	.800
Training & Development	.229	.781	.262	.262	.837
Supervisor Ratings	.217	.203	.874	.169	.895
Performance Appraisal System	.132	.136	.856	.135	.929
Participative Management	.174	.271	.810	.216	.887
Grievance Redressal	.218	.294	.802	.218	.887
Job Security	.167	.202	.208	.904	.894
Compensation Benefits	.140	.198	.202	.892	.862
Recognition and Motivation	.228	.288	.220	.839	.800
<b>Cronbach's Alpha</b>	<b>0.96</b>	<b>0.96</b>	<b>0.94</b>	<b>0.92</b>	
<b>Eigen value</b>	<b>8.067</b>	<b>1.823</b>	<b>1.524</b>	<b>1.355</b>	
<b>% of Variance</b>	<b>53.777</b>	<b>12.150</b>	<b>10.162</b>	<b>9.036</b>	
<b>Total % of Variance</b>	<b>85.12</b>				

Source: primary data

The KMO and Bartlett's Test displays the results for interpreting the adequacy of data for factor analysis. Kaiser-Meyer-Olkin (KMO) is a measure of sampling adequacy and its value should be greater than 0,6 for the sample to be adequate for undertaking factor analysis. Also, the p-value of Bartlett's test is .000 (less than .005), thus, the hypothesis that the correlation matrix is an identity matrix can be rejected, that is, the correlation matrix has significant correlations among at least some of the variables. Hence factor analysis can be undertaken using this dataset.

The communalities column presents the communality of each variable (i.e, the proportion of variance in each variable accounted for by the common factors). In using the principal component method for factor extraction, it is possible to compute as many factors as there are variables. When all factors are included in the solution, all of the variance of each variable is accounted for by the

common factors, thus, the proportion of variance accounted for by the common factors, or the communality of a variable, is 1 for all the variables.

The Total Variance Explained rows present the number of column factors extracted, the eigen values associated with these factors, the percentage of total variance accounted for by each factors, and the cumulative percentage of total variance accounted by the factors. Using the criterion of retaining only factors with eigen values of 1 or greater, three factors were retained for rotation. These four factors accounted for 53.77%, 12.15% , 10.162% and 9.036 of the total variance, respectively, for a total of 85.123%.

In the Rotated Components Matrix, each number represents the partial correlation coefficient between variable and the rotated component. These coefficients help in identifying the components. All the variables that have large factor loadings for a given component define the component.

The variables constituting components 1 are:

- Pay leave facilities
- Hygiene work facilities
- Travel facilities
- Recreation facilities

The variables constituting component 2 are:

- Company Image
- Role Clarity
- Work Climate
- Training & Development

The variables constituting component 3 are:

- Supervisor Ratings
- Performance Appraisal System
- Participative Management
- Grievance Redressal

The variables constituting component 4 are:

- Job Security
- Compensation Benefits
- Recognition and Motivation

The result of principal Component Analysis reveals that the four organisational factors

- Environmental factor
- Job factor
- Leadership role factors
- Compensation factors

Thus, I.T industry employees are focusing these four organisational factors for their job. satisfaction

## Confirmatory Factor Analysis for the employees satisfaction on organisational factors in I.T industry.

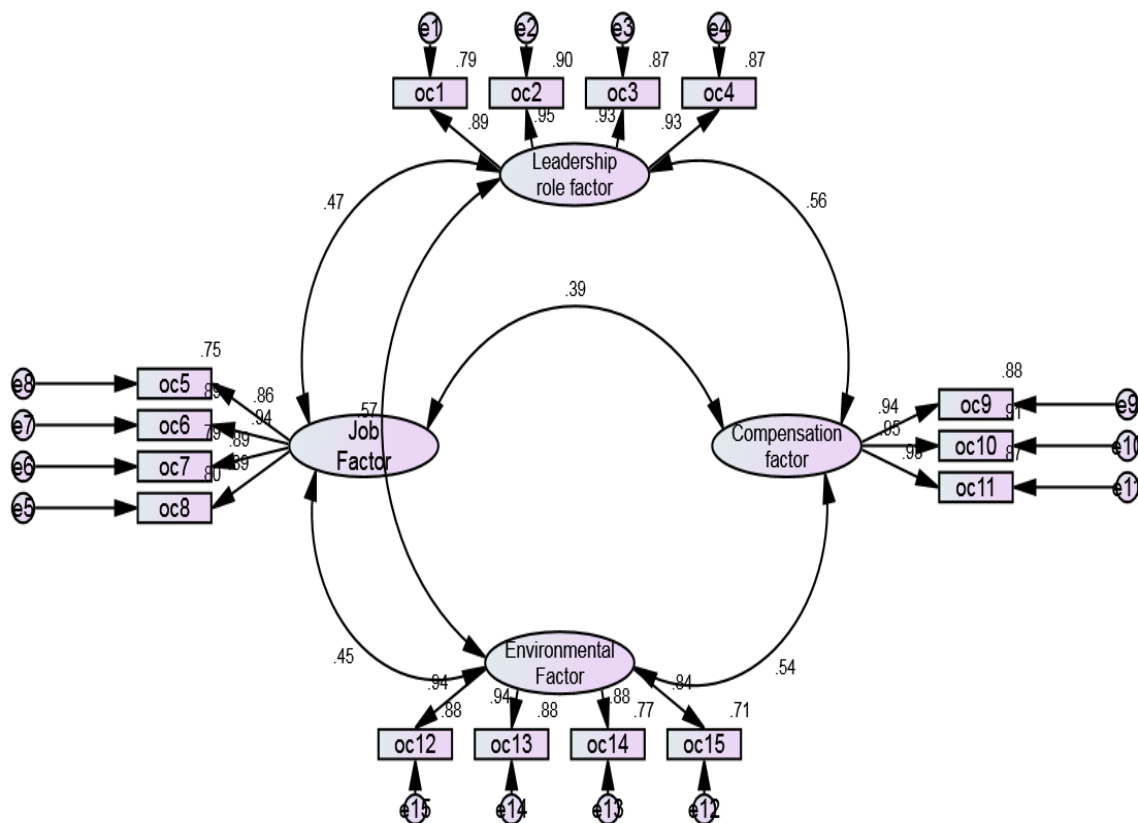

## Measurement Model

Table  
Model fit summary

Indices	Value	Suggested Value
CMIN	164/84 = 1.956	< 5
P Value	0.32	> 0.05 (Hair et al,1998)
GFI	0.892	> 0.80(Hair et al, 2006)
AGFI	0.846	> 0.80 (Hair et al, 2008)
CFI	0.892	> 0.80 (Hair et al,2008)
RMSEA	0.047	< 0.05 (Hair et al,2006)

A confirmatory factor analysis has been performed, based on data from 430 I.T employees. Maximum likelihood estimation was chosen because data were normally distributed. Normality and linearity were checked to evaluate the assumptions of multivariate. Cutoff Criteria for Several Fit Indexes Shorthand General rule for acceptable fit if data are continuous.

The parameters are estimated by maximum likelihood (ML) methods rather than by ordinary least squares (OLS) methods. OLS methods minimize the squared deviations between values of the criterion variable and those predicted by the model. ML (an iterative procedure) attempts to maximize the likelihood that obtained values of the criterion variable will be correctly predicted..

GFI, the goodness of fit index, indicates the proportion of the variance in the sample variance-covariance matrix is accounted for by the model. This should exceed 0.8 for a good model. For the saturated model it will be a perfect 1. AGFI (adjusted GFI) is an alternate GFI index in which the value of the index is adjusted for the number of parameters in the model. The fewer the number of parameters in the model relative to the number of data points (variances and covariances in the sample variance-covariance matrix), the closer the AGFI will be to the GFI. The PGFI (P is for parsimony), the index is adjusted to reward simple models and penalize models in which few paths have been deleted. Note that for our data the PGFI is larger for the independence model than for our tested model.

PRATIO is the ratio of how many paths dropped to how many could have dropped. The Parsimony Normed Fit Index (PNFI) is the product of NFI and PRATIO, and PCFI is the product of the CFI and PRATIO. The PNFI and PCFI are intended to reward those whose models are parsimonious. The Root Mean Square Error of Approximation (RMSEA) estimates lack of fit compared to the saturated model. RMSEA of .05 or less indicates good fit, and .08 or less adequate fit. PCLOSE is the p value testing the null that RMSEA is no greater than 0.05. Chi-square  $\chi^2$  Ratio of 164 (df, 84), useful for nested models/model trimming

We hypothesized a two-factor model to be confirmed in the measurement portion of the model. There were no missing data. The Goodness of fit index (GFI) =0 .892 and the RMSEA = .047. Those values indicate a good fit between the model and the observed data.

The goodness-of-fit test statistics are displayed below. The Chi-square test statistic is significant at 0.05, which suggest that the model fitting is good fit. Root mean square error of approximation (RMSEA) is 0.047 which reveal lesser error status, it indicates a good fit. Goodness of Fit Index (0.892) and Adjusted Goodness of Fit Index (.846) are larger than 0.8 which again reflect a good fit. No modifications have been done.

**Table**  
**Table of Average Variance Extracted and Construct Reliability**

			Estimate	Item reliability	AVE	Delta	CR
oc1	<---	Leader	0.887	0.787	0.856 (85.6%)	0.213	0.96
oc2	<---	Leader	0.949	0.901		0.099	
oc3	<---	Leader	0.932	0.869		0.131	
oc4	<---	Leader	0.932	0.869		0.131	
oc8	<---	Job	0.895	0.801	0.804 (80.4)	0.199	0.94
oc7	<---	Job	0.887	0.787		0.213	
oc6	<---	Job	0.942	0.887		0.113	
oc5	<---	Job	0.863	0.745		0.255	
oc9	<---	compensation	0.94	0.884	0.886 (88.6)	0.116	0.96
oc10	<---	compensation	0.953	0.908		0.092	
oc11	<---	compensation	0.932	0.869		0.131	
oc15	<---	environment	0.843	0.711		0.289	
oc14	<---	environment	0.879	0.773	0.811 (81.1)	0.227	0.93
oc13	<---	environment	0.941	0.885		0.115	
oc12	<---	environment	0.936	0.876		0.124	

#### Average Variance Extracted:

A good rule of thumb is an AVE of 0.5 or higher indicates adequate convergent validity. An AVE of less than .5 indicates that on average, there is more error remaining in the items than there is variance explained by the latent factor structure you have imposed on the measure.

#### Construct Reliability:

The rule of thumb for a construct reliability estimate is that .7 or higher suggests good reliability. Reliability between .6 and .7 may be acceptable provided that other indicators of a model's construct validity are good. A high construct reliability indicates that internal consistency exists. This means the measures all are consistently representing something.

**Table**  
**Discriminant Validity**

	Leadership role	Job factors	Compensation factors	Environmental factors
Leadership role	0.8562			
Job factors	0.222	0.80498		
Compensation factors	0.314	0.15	0.88681	
Environmental factors	0.32	0.2	0.295	0.81122

All variance extracted (AVE) estimates in the above table are larger than the corresponding squared inter construct correlation estimates (SIC). This means the indicators have more in common with the construct they are associated with than they do with other constructs.

## SUMMARY OF FINDINGS, SUGGESTIONS AND CONCLUSION

### FINDINGS

1. All variance extracted (AVE) estimates larger than the corresponding squared inter construct correlation estimates (SIC). This means the indicators have more in common with the construct they are associated with than they do with other constructs.
2. The findings received through the conducted Mann-Whitney U test. Here the researcher has separated the employees under gender basis and analysed their satisfactory level and vital factors which has created their influence on it. Amidst of the male and female employees the researcher analysed the impact of satisfactory factors on them.
3. Amidst of the penta satisfactory factors, the four satisfactory factors as Compensation factors, Job factors, organisation factors and leadership role factors received the p value of .000 which is lesser than 0.05 and it defines the existing statistically mean significant difference. Environmental factor is the one and only factor with the p value of .010 Hence here all of the satisfactory factors with their p value which is lesser than 0.05 brings out the prevailing statistically mean significant difference.
4. Overall table and findings can be consummated that, the male employees are much more satisfied than the female employees. Hence required steps are very important in order to achieve the zeal satisfactory level.

## 2 SUGGESTIONS

### For the companies

- 1) The first and foremost factor that influences the depression level of an employee is the monetary benefits that he gets for the works that he renders. Therefore from the part of the company it is necessary to provide compensation benefits in fair manner. The compensation benefits can be properly distributed based on their work load and their experience. While employing a new employee, the companies can make sure that the compensation benefit paid to the new employee is on par with the already existing employees or slightly above but not a lot higher than the existing employees.
- 2) The second factor that the employee expects from a company is job security. The I.T. industry is notorious for its lack of job security. Whenever the company is facing any loss economically, it is directly thrust upon the employees and they are thrown out of the job in order to maintain their economic status. Therefore, if the I.T. companies can provide some kind of job security, it can greatly reduce the depression level of the employees.

### For the Team Leader

- 1) From the part of the team leader he/she may follow certain practices in order to keep in check the depression level of the employees. The first and the foremost thing a leader can have is equality. He may treat all his team members equally so that none of them have inferiority complex or superiority complex. If any of the employees feel that they are not treated on par with their other employees, he might lose interest in the company that he is working for or his depression level might increase. Therefore it is the team leader's job to make sure all the employees are treated equally.
- 2) Work load is an important factor that can give rise to depression among the employees. A good team leader can make sure that the work is evenly distributed among the team members and no one is burdened with heavy work while others are enjoying leisurely.
- 3) A team leader is requested to submit a report regarding his team members before the performance appraisal is done by the company. The team leader may be very careful while submitting this report. And moreover, if any of the team member is making any mistakes, then the mistakes should be highlighted immediately so that the employee can rectify it. The team leader should not wait until the performance appraisal to highlight the problems and mistakes of the team members. This might end up as a fault finding act rather than a performance increasing act.

### For the Employees

1. In order avoid depression, the employees on their part should also follow some habits and activates, they cannot wait for either the company or the team leader. In order to avoid the lifestyle related diseases, the employees can make sure that they don't sit for a long stretch at a time. They may make it a habit to have some kind of movement every half an hour so that there is no monotony in their working habit.
2. Waking up early in the morning and going to bed early is a good habit that everyone may follow, especially the I.T. employees. Having a good night's sleep without any stress or disturbances from the modern equipment such as the mobile phones can greatly help in reducing the depression level of an employee.
3. The employees may make sure that they spend some quality time with their family members. Spending time with the family and having some happy time either in their home or going for tour or excursion along with their family members can reduce their depression levels considerably.
4. If the work that you do doesn't make you happy or satisfied, then it is time for the employee to either find ways to make it interesting or find a new job. One of the major reason for depression is doing job that is not interesting to the employee and they may at any cost try to avoid it.



### 3 CONCLUSION

In the present context, the world economy is mostly based on the field of information technology. Various companies including the world's richest person is reliant on information technology. This has led to an enormous increase in the emergence of I.T. companies that caters to the technological need of the world. Though it started in the Silicon Valley of America, it later spread throughout the world. In India, there are many I.T. hubs and Chennai is one among them. For an industry with such a vast presence throughout the world, the necessity to keep its employees happy is paramount. When the workers are happy and content, they will work hard for the overall improvement of the industry. But if the workers are not happy and depressed, then it is a bad sign for the industry. Therefore it is the necessity for the researchers to analyse the various problems faced by them that can lead to depression and provide solutions to rectify those problems.

### BIBLIOGRAPHY

- [1] A.K. Sharma (2003) conducted a study about "Computer Related Health Problems among Information Technology Professionals in Delhi", CME vol.31:issue 1.
- [2] Bharathi T (2017), "Job Stress and Productivity: A Conceptual Framework", International Journal of Emerging Research in Management & Technology ISSN: 2278-9359 (Volume-6, Issue-8).
- [3] Branda Pinto, Dr. Shrutin Ulman and Ms Harneet Assi (2004), "Prevalence of Occupational Diseases in Information Technology Industries in Goa", (Paper presented at the 54th National Conference – IAOH, Kochi, 2004
- [4] Cryer, Bruce, McCraty, Rollin and Childre, Doc, Managing Yourself- Pull the Plug on Stress. Harvard Business Review, July, 2003.
- [5] Curtis, K, Managing Stress: Learn the warning signs before your life spins out of balance. Broker Magazine July: 30, 2006.
- [6] D. S. Madhumathi (2002), "Infertility - an occupational hazard?", Business Line, Tuesday, Dec.17, 2002."
- [7] Krishnamurthy (2004), "For some time kind of work is seen as a step towards a job in the more respected and an accepted software industry".